

EASY ACCESS

From your personal phone:

- Pick up the receiver
- Press *99
- Enter your password

OR

From any other phone:

- Dial (204) 225-9999
- Press # if you are calling from a phone that does not have Call Answer or Press * if the line you are calling from also has Call Answer
- Enter your 10-digit mailbox number followed by your password

Note: Your mailbox number is your area code and your 7-digit telephone number.

HANDY TIPS

Once in your mailbox, press:

- 1 To listen to all messages
- 1-1 To listen to new messages
- 2 Send a message directly to another mailbox
- 4 Personal options

While reviewing your messages, press:

- 1 Rewind 10 seconds
- 1-1 Rewind to beginning of message
- 3 Fast forward 10 seconds
- 3-3 Fast forward to end of message
- # Skip to next message at any time

After reviewing your messages, press:

- 4 Replay message
- 5 Envelope information
- 6 Forward a copy to another mailbox
- 7 Erase message
- 8 Reply to message
- 9 Save message
- * Exit to Main Menu or to exit system

*Note: After retrieving your messages, ensure to save or delete any new messages, and exit your mailbox by using *. This will ensure the message waiting light will turn off.*

CALL MONITOR

Call Monitor is available to Call Answer customers on a Pay Per Use basis for 15¢ per use. Call Answer Plus subscribers may use Call Monitor free of charge.

When your phone goes unanswered, a short ring will alert you once a call has been transferred to your mailbox.

To find out who is calling and listen without being heard:

- Pick up the receiver
- Press *95

Call Answer Plus subscribers may simply pick up the receiver or press the disconnect button – you do not have to dial *95.

If you want to speak with your caller:

- Press the [LINK](#) or disconnect button

If you do not want to speak with your caller:

- After listening, hang up.

RING CONTROL

To have callers go to your mailbox:

- Pick up the receiver, press *90

To have callers get a busy signal:

- Pick up the receiver, press *91

To turn Call Answer service on or off:

- **To turn on** – Pick up the receiver, press *92
- **To turn off** – Pick up the receiver, press *93

To change the number of rings before callers are forwarded to Call Answer:

- Press *94
- Listen for the tone
- Enter 0-9 to set the number of rings

Note: a confirmation tone will sound to indicate that the change has been made.

Visit www.mts.ca for more information.

MTS design mark is a registered trade-mark of Manitoba Telecom Services Inc., both used under license.

775/July 2011

CALL ANSWER SERVICE

Quick Reference Guide



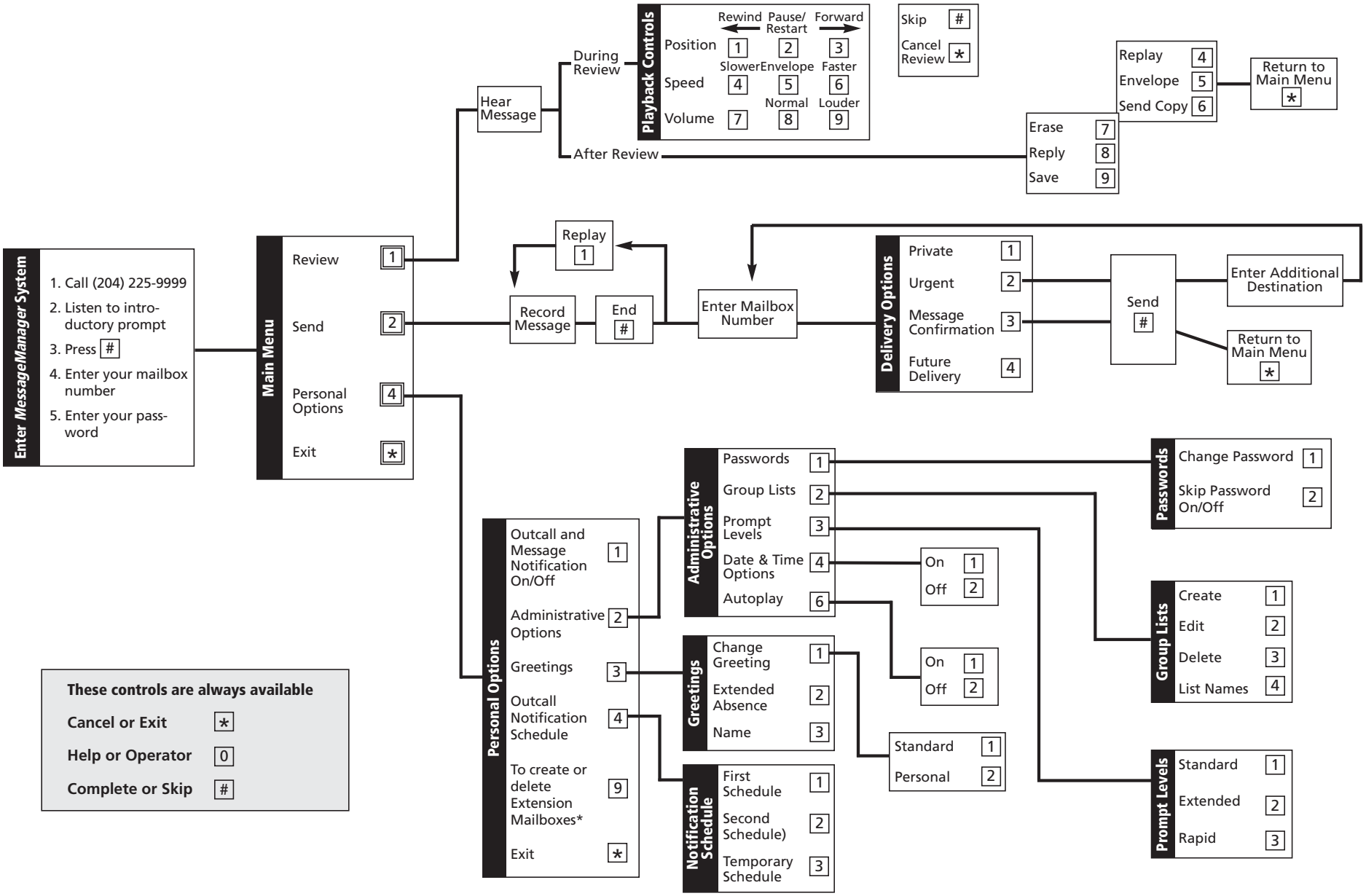

These controls are always available

- Cancel or Exit *
- Help or Operator 0
- Complete or Skip #

* Extension mailboxes available only with Call Answer Plus.